

Semiconductor Devices - 2014

Lecture Course
Part of
SS Module PY4P03

Dr. P. Stamenov

School of Physics and CRANN, Trinity College,
Dublin 2, Ireland

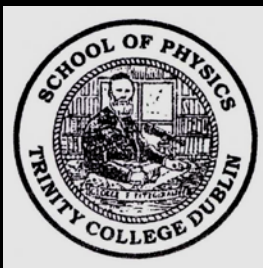
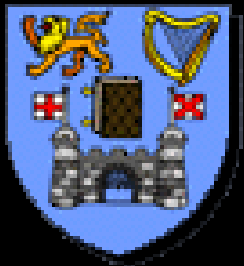

Hilary Term, TCD
24th of Jan '14



Diode Current Components

$$-\frac{p_n - p_{n0}}{\tau_a} + D_a \frac{\partial^2 p_n}{\partial x^2} - \frac{n_n - p_n}{n_n/\mu_p + p_n/\mu_n} \mathcal{E} \frac{\partial p_n}{\partial x} = 0$$

$$D = \frac{k_B T}{q} \mu = V_t \mu$$

$$D_a = \frac{n_n + p_n}{n_n/D_p + p_n/D_n}$$

Using Einstein's Relation

Ambipolar Lifetime

$$\tau_a = \frac{p_n - p_{n0}}{U} = \frac{n_n - n_{n0}}{U}$$

Ambipolar Diffusion Coeff.

$$-\frac{p_n - p_{n0}}{\tau_p} - \mu_p \mathcal{E} \frac{\partial p_n}{\partial x} + D_p \frac{\partial^2 p_n}{\partial x^2} = 0$$

Low Electric Field Approximation - 1D Diffusion Eq.

$$\frac{\partial^2 p_n}{\partial x^2} - \frac{p_n - p_{n0}}{D_p \tau_p} = 0$$

Small Injection Approximation ($D_p = D_n = D_a$)

Diffusion Limited Currents

Diffusion Exponent

$$L_p = \sqrt{D_p \tau_p}$$

Hole Diffusion Length

$$p_n - p_{n0} = p_{n0} \left(e^{qV_a/k_B T} - 1 \right) e^{-(x-x_n)/L_p}$$

$$J_p = -qD_p \frac{\partial p_n}{\partial x} \Big|_{x_n} = \frac{qD_p p_{n0}}{L_p} \left(e^{qV_a/k_B T} - 1 \right)$$

$$J_n = -qD_n \frac{\partial n_p}{\partial x} \Big|_{-x_p} = \frac{qD_n n_{p0}}{L_n} \left(e^{qV_a/k_B T} - 1 \right)$$

Partial currents of holes and electrons

This much survives on the other side of the diffusion tails

$$J_s = \frac{qD_p p_{n0}}{L_p} + \frac{qD_n n_{p0}}{L_n}$$

Saturation Current

$$J = J_p + J_n = J_s \left(e^{qV_a/k_B T} - 1 \right)$$

The Total Current

The Ideal World and Its Imperfections

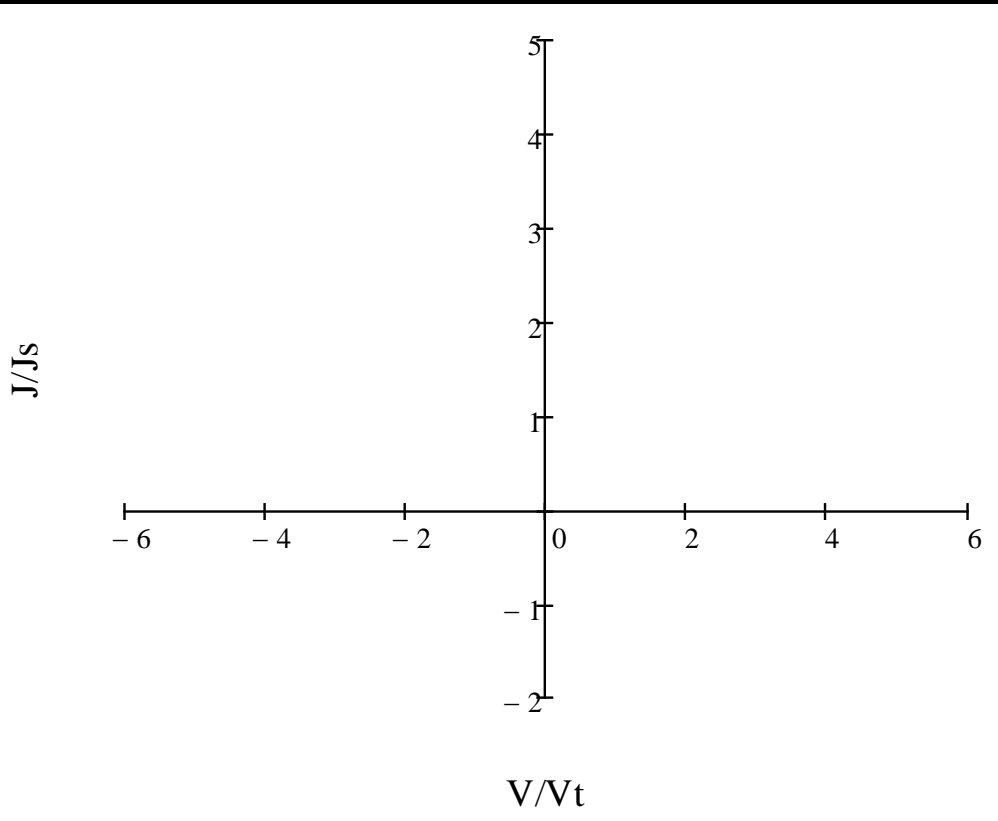

$$\frac{J}{J_s} = \left(e^{V_a/\eta V_t} - 1 \right)$$

- The ‘ideal’ dependence is NOT valid even for the ‘best’ diodes at room temperature and arbitrary bias.
- The voltage activation scale is ηV_t and not V_t .
- In most cases the ‘ideality factor’ is closer to 2 rather than 1, because of large recombination/generation current components.
- Large currents ‘kick-in’ above V_{bi} (say 0.5 V), however most approximations fail soon above that.
- Reverse bias saturation is not perfect in practice – eventually ionisation breakdown.

Some Remarks on Diodes

- In practical applications, two parameters are of great importance – forward voltage drop and reverse leakage current.
- In view of its smaller band gap $E_g(\text{Ge}) \sim 0.7 \text{ eV}$, compared to $E_g(\text{Si}) \sim 1.1 \text{ eV}$, Ge diodes have higher reverse bias leakage currents (deep recombination).
- However, for Ge the forward voltage drop is lower as $V_{\text{bi}}(\text{Ge}) \sim 0.3 \text{ V}$, and this implies lower internal losses and therefore less overall heating – often important in high-power circuits.
- The difference is also important in ‘clipping’ circuits – i.e. overdrive and distortion pedals – *for the guitar players out there, it makes a real difference.*

Epitaxial Bipolar Transistor

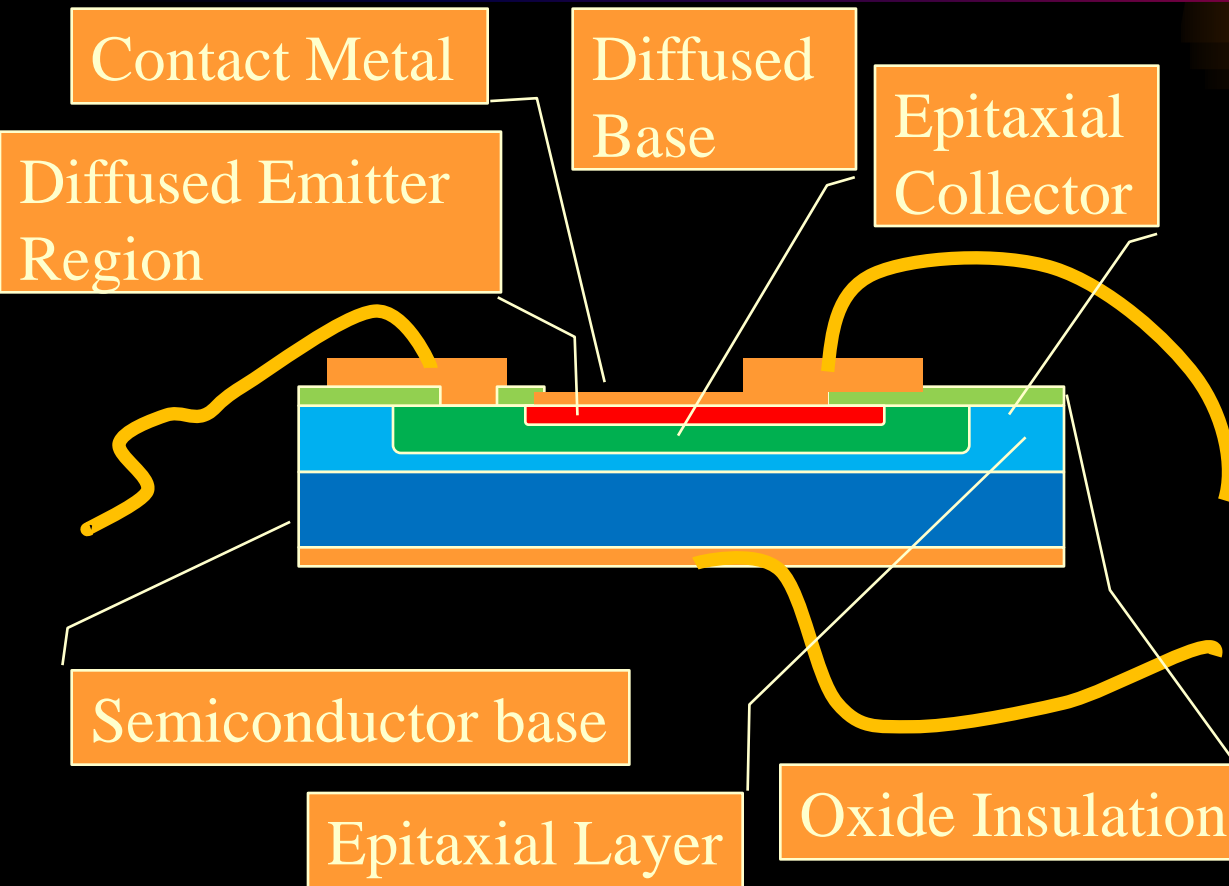

Recipe

- ...
- Grow an epilayer
- Oxidize
- Diffuse from a limited source
- Diffuse from a constant source
- ...

Features

- Building block
- Provides gain
- Current-control device
- Bipolar device

- Usually the base is created thin, in order to achieve high current and power gain
- The secondary junction formed (say nn^+) is normally perfectly ohmic

Bipolar Transistor – Doping Profile

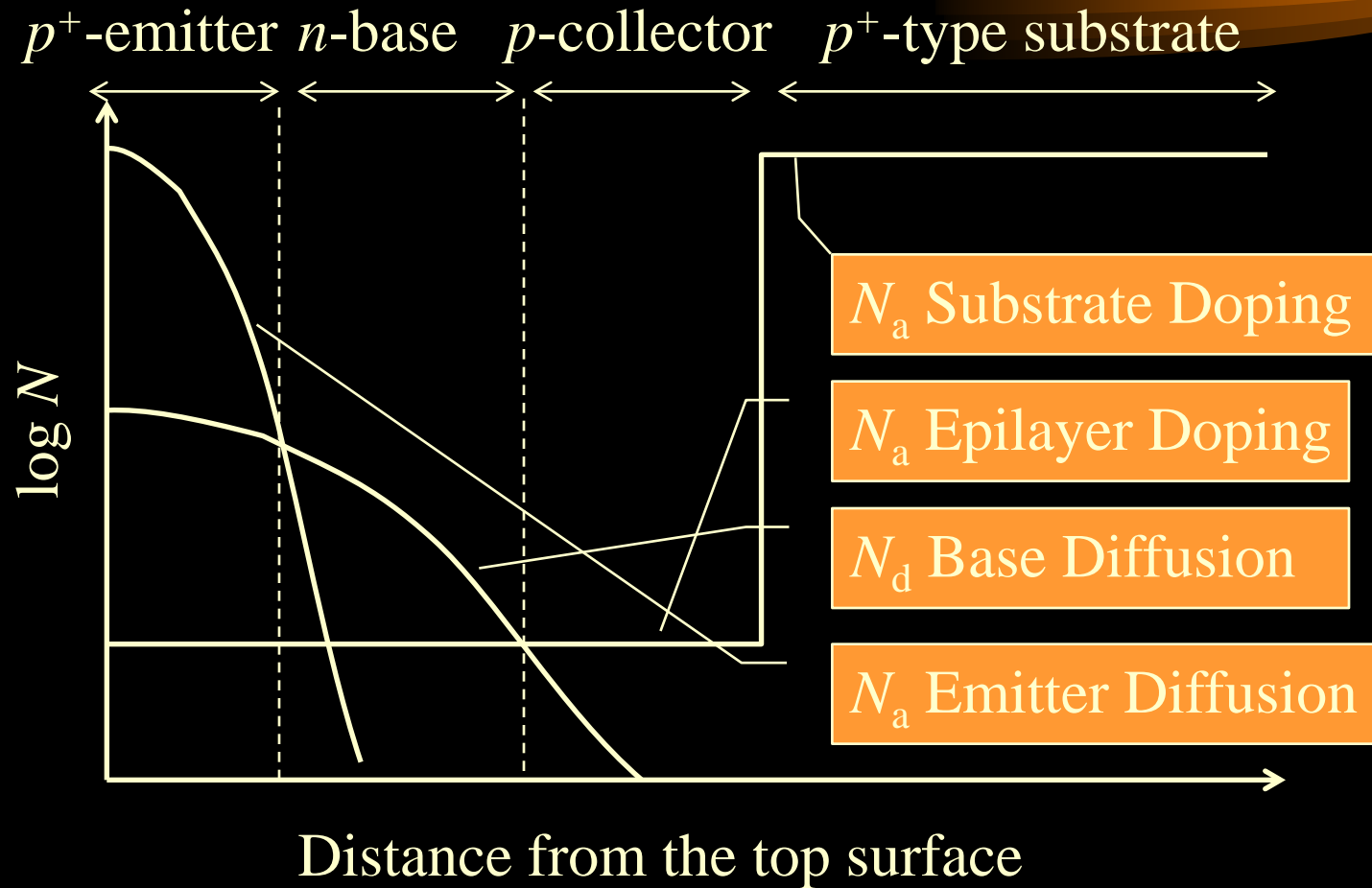

- Two distinct diffusion steps have to be performed – diffusion from a finite source (with or without drive-in) and constant source
- Obviously, it would be easier to realize the n - p - n on an n -wafer.

Structure and Operation

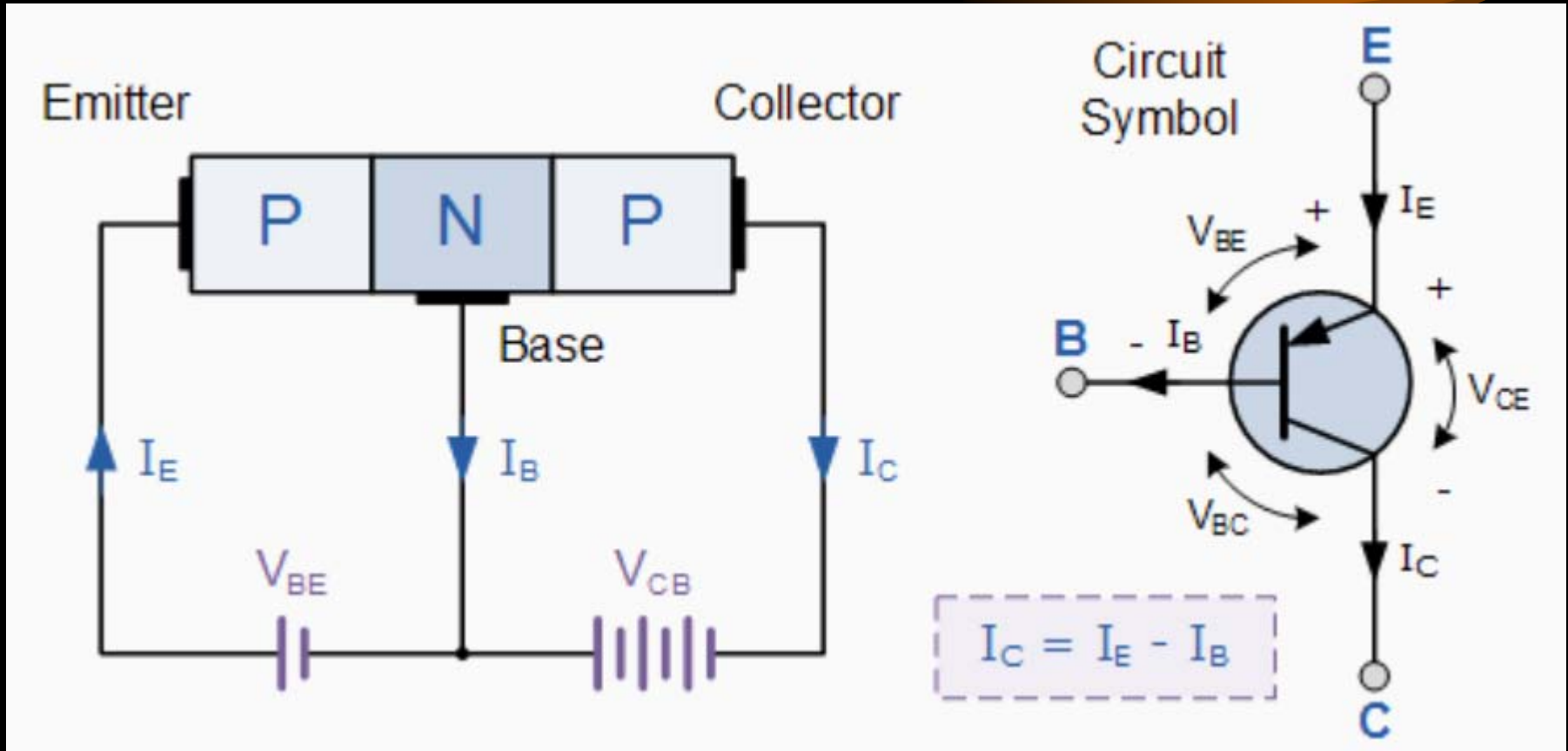

http://www.electronics-tutorials.ws/transistor/tran_3.html

- Note the bias conventions and the correspondence to the circuit symbol. The *n-p-n* version is the same up to a sign change.
- Note, that in normal operation $I_B < I_C$.

Notes on BJT's

- The first commercial solid state amplifier (1947)
- Nowadays 'almost obsolete' – replaced primarily by FETs.
- Still used, however, in some high-power and high speed applications.
- Modern BJT's use epitaxial, planar construction.
- Two flavours $p-n-p$ and $n-p-n$. The underlying physics is the same. However the $n-p-n$ ones can be somewhat faster. *Why?*
- The amplification is due to the flow of minority carriers into the base region.

From Two Diodes to a Transistor

Common emitter configuration

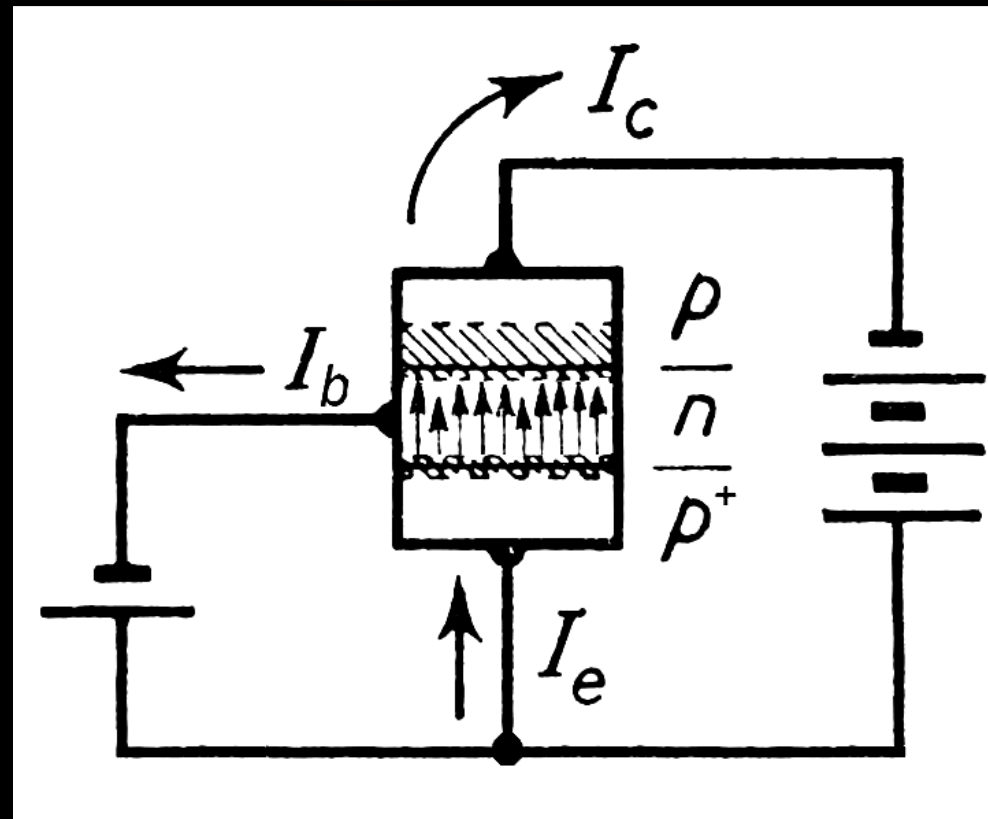
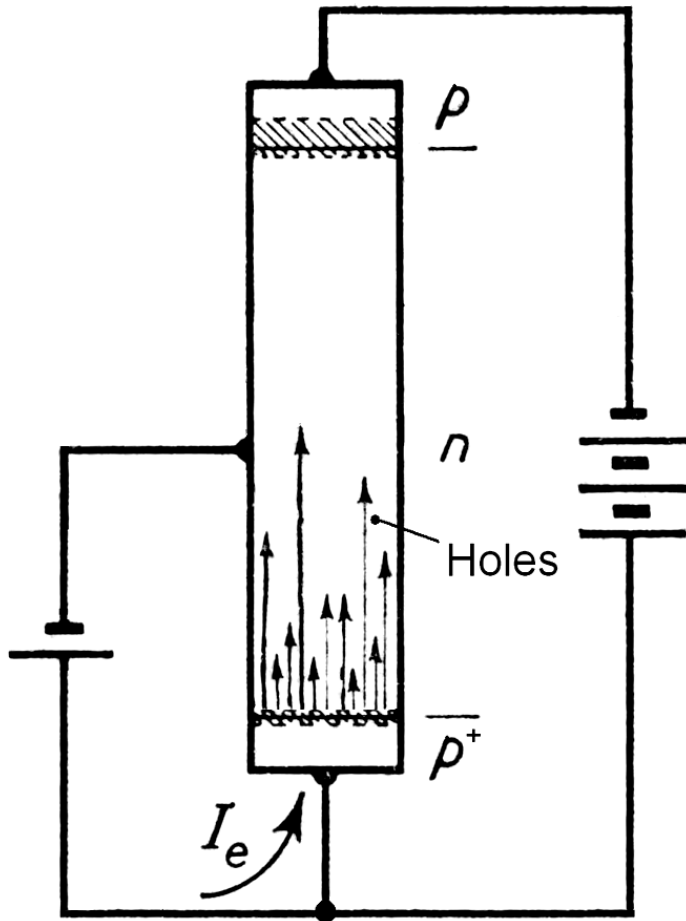

- Two diodes in opposition do not make a transistor. The minority carriers will recombine before reaching the build-in field region of the second junction.

Focus on Common Emitter

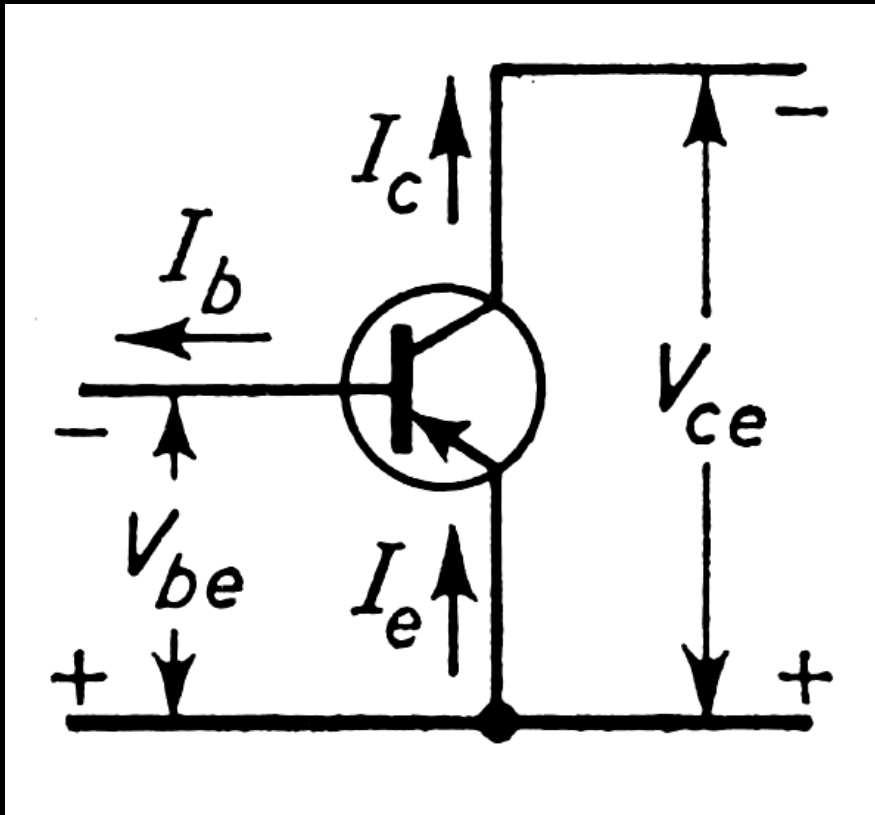

- Why is power gain so important?
- Where is the power coming from? DC and AC operation.
- Why is the transistor called a 'transistor'?

- The base-collector junction is usually made physically larger than the emitter-base one, for the geometric collection efficiency.
- The collector and emitter currents are almost equal and large.
- The input (base) current is small.
- $I_c/I_b > 10^2$ in most 'modern' bipolar transistors.
- For practice – think about all three connection options – common base, common emitter and common collector. Which ones have current gain? Which ones have voltage gain?

Actual Impurity Concentration Profiles

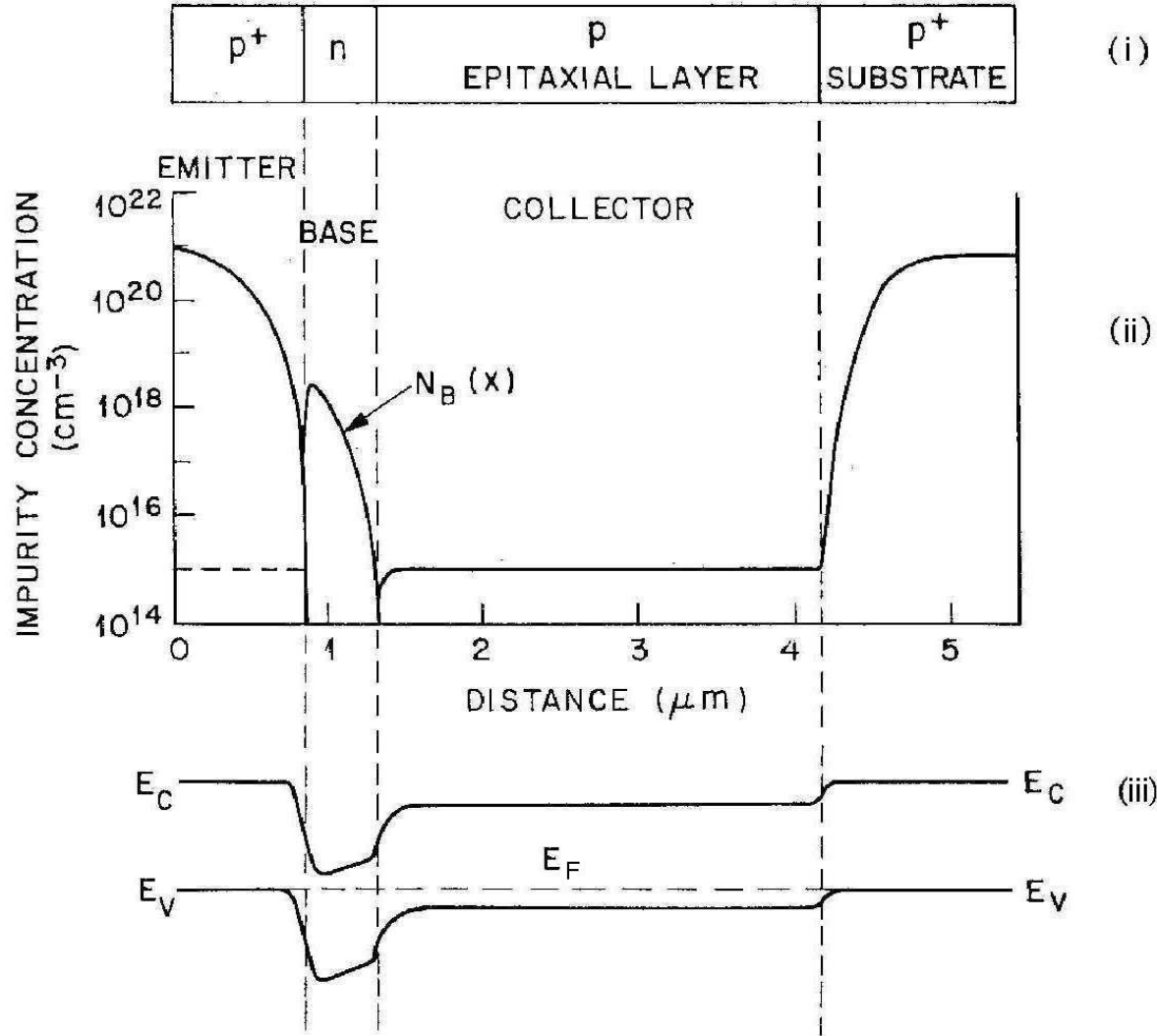

- (i) Cross-sectional view of a diffused bipolar transistor.
(ii) Net impurity distribution in transistor.
(iii) Corresponding band diagram in thermal equilibrium.

- (i) • Role of the concentration gradients.
- (ii) • Build-in fields as large as $100 \text{ mV}/\mu\text{m}$
- Minority carrier drift and diffusion.
- Minority carrier recombination losses.
- (iii) • Minority carrier transit times – can gain orders of magnitude.

Base Transit Time

- The hole drift velocity v_p in the base is given by $v_p = \mu_p E_b$, where the hole mobility $\mu_p = 0.05 \text{ m}^2 \text{ V}^{-1} \text{ s}^{-1}$ in silicon.
- The transit time τ_b across the base, width w_b , is approximately:

$$\tau_b = \frac{w_b}{v_p} = \frac{w_b}{\mu_p E_b} = \frac{1.10^{-6}}{0.05 \times 0.2.10^6} = 1.10^{-10} \text{ s} = 100 \text{ ps}$$

for a base width w_b of $1 \text{ } \mu\text{m}$ (and neglecting diffusion).

- Frequency responses ($\approx 1/(2\pi\tau_b)$) up to the GHz region can be expected – depending on the circuit.
- Much faster special BPTs exist, as will be seen later.

Thanks and Acknowledgements



Thank You Very Much for Your Attention!